

SUBMITTAL DATA

KULA09HPJ11B / KULA09HPJ10B
9000 BTU/H Wall Mounted Heat Pump System

Job Name

Purchaser

Submitted to

Unit Designation

Location

Date

Engineer

For

Schedule No.



KULA09HPJ11B



KULA09HPJ10B



YAP1F7F



XE71 (Optional)

GENERAL FEATURES

- AHRI Certificate: [213829842](#)
- High Efficiency DC Inverter Technology
- Compact and Quiet Design
- Auto-Clean Function on Indoor Unit
- Wireless Remote with LCD Display
- Wired Controller Options
- Wi-Fi Included (Factory Installed)
- Low Ambient Cooling down to -20°F (Range -20°F to 122°F)
- Low Ambient Heating down to -22°F (Range -22°F to 86°F)
- Coil (Indoor and Outdoor) Copper Tube / Aluminum Fin
- Blue Colored Fin - 500 Hrs Salt Spray Tested

SPECIFICATIONS, FEATURES & FUNCTION SUMMARY

SPECIFICATIONS KULA09HPJ11B / KULA09HPJ10B

System Type HEAT PUMP

SYSTEM PERFORMANCE

Cooling	Min - Max	Btu/h	1535 - 10747
	Capacity @95°F	Btu/h	9100
Heating	Min - Max	Btu/h	3412 - 14672
	Capacity @5°F	Btu/h	9100
	Capacity @17°F	Btu/h	7000
	Capacity @47°F	W	10500
SEER2			25.5
EER2			14.7
HSPF2			10.2
COP @5°F			1.9
COP @47°F			3.9
Cooling Temperature Range	°F		-20 - 122
Heating Temperature Range	°F		-22 - 86
Refrigerant Type			R410A

INDOOR UNIT

KULA09HPJ11B

Air flow (Min-Max)	CFM	159 - 353
Sound Pressure Level (Min - Max)	dB(A)	25 - 40
Dehumidification	pt/hr	1.69
External Dimensions (WxHxD)	in	32-1/2 × 11-9/16 × 7-3/4
Package Dimension (W x H x D)	in	34-7/16 × 14-3/8 × 10-9/16
Net Weight	lbs	20.9
Gross Weight	lbs	25.4

OUTDOOR UNIT

KULA09HPJ10B

Compressor Type		G-10 / 2 - STAGE INVERTER
Sound Pressure Level	dB(A)	52
External Dimensions (WxHxD)	in	31-5/8 × 21-7/8 × 13-13/16
Package Dimension (W x H x D)	in	34-3/8 × 24-7/16 × 15-11/16
Net Weight	lbs	70.6
Gross Weight	lbs	76.1

REFRIGERANT PIPING

Refrigerant Charge - R410A	oz	35.3
Additional Charge	oz/ft	0.2
Line Set Size (Liquid - Gas) - Flared Connections	in	1/4 - 3/8
Pre-Charge Length	ft	25
Pipe Length (Min - Max)	ft	10 - 66
Max. Pipe Elevation	ft	40

ELECTRICAL

Power Supply	208-230V / 1Ph / 60Hz (Powered by the Outdoor Unit)	
Voltage Range (Min - Max)	VAC	187 - 253
Rated Current - Cooling	A	4.7
Rated Current - Heating	A	6
MCA	A	10
MOCP	A	15
Suggested Breaker Size	A	10
Main Power Wire Size	AWG	Per Local Code
Interconnecting Wire Size	AWG	14 / 4

FEATURES & FUNCTIONS SUMMARY

KULA09HPJ11B / KULA09HPJ10B

SYSTEM FEATURES

Inverter Type	G10
Ultra Low Frequency Torque Control	Yes
Power Factor Correction	Yes
Compressor Type - Inverter	High Efficiency Rotary
Basepan With Electric Heater	Yes
Indoor & Outdoor Fin Coating (Blue Fin)	Yes
Intelligent Defrosting	Yes
Intelligent Preheating	Yes
Low Voltage Startup	Yes
Memory/Power Failure Recovery	Yes
Self Diagnosis	Yes
Wired Controller Interface (XE71 or XK76 optional)	Yes
WiFi Included	Yes
NEW! Easy Service Access	Yes
Indoor Fan Type	Crossflow
Multi Fan Speeds	7 Speeds
Indoor Unit Display	Yes
Auxiliary Electrical Heater	No
Ventilation (Outdoor Air)	No

REMOTE CONTROLLER FUNCTIONS

NEW! Auto Clean	Yes
Auto Mode	Yes
Auto Fan	Yes
Auto Swing (Horizontal Auto Swing)	Yes
Auto Swing - 180° (Vertical Auto Swing)	Yes
Clock	Yes
Dry Mode	Yes
Dry Anti-Mildew (X-Fan) Mode	Yes
Energy Saving Mode	Yes
Dirty Filter Alert	No
Fan Speed Control (7 Speeds)	Yes
I Feel Function	Yes
Privacy Lock	Yes
Quiet Mode	Yes
Room Temperature Display	No
Sleep Mode	Yes
3 Sleep Mode Options	Yes
Timer Mode	Yes
Turbo Mode	Yes
Display On/Off Control	Yes
Freeze Guard Mode	Yes
Power Failure Mode	Yes

DIMENSIONS

INDOOR UNIT

Unit: inch

KULA09HPJ1IB	
DIMENSIONS	
W	32-31/64
H	11-17/32
D	7-23/32
W1	4-29/64
W2	21-11/32
W3	6-11/16

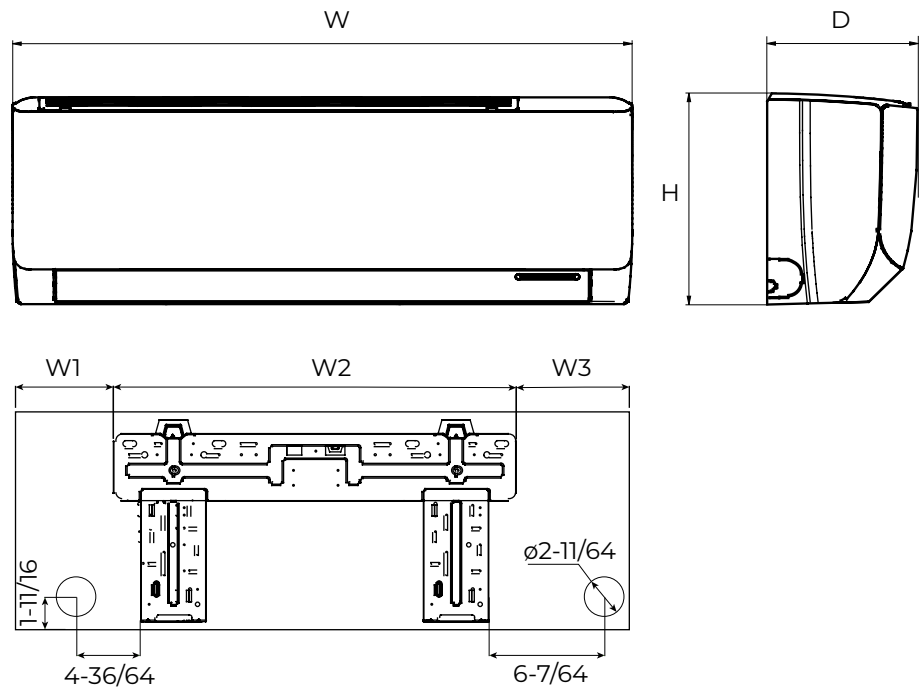

OUTDOOR UNIT

Unit: inch

KULA09HPJ1OB	
DIMENSIONS	
A	29-21/64
B	31-37/64
C	21-27/32
D	11-13/16
E	13-25/32
F	20-5/32
G	13-5/64

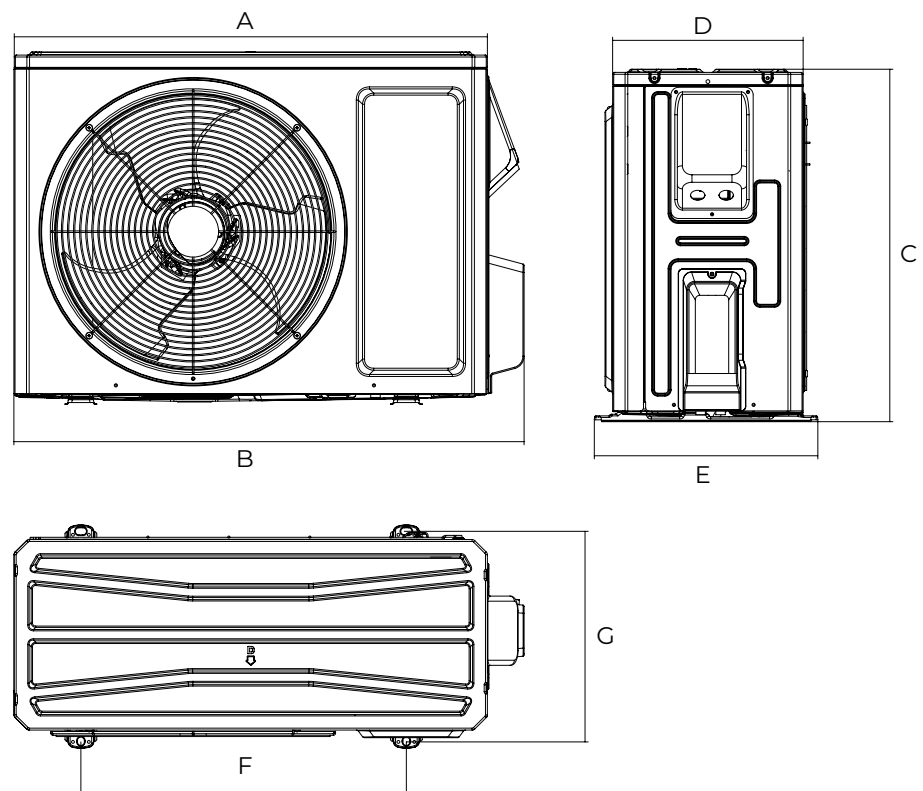

CLEARANCES

INDOOR UNIT Minimum clearance

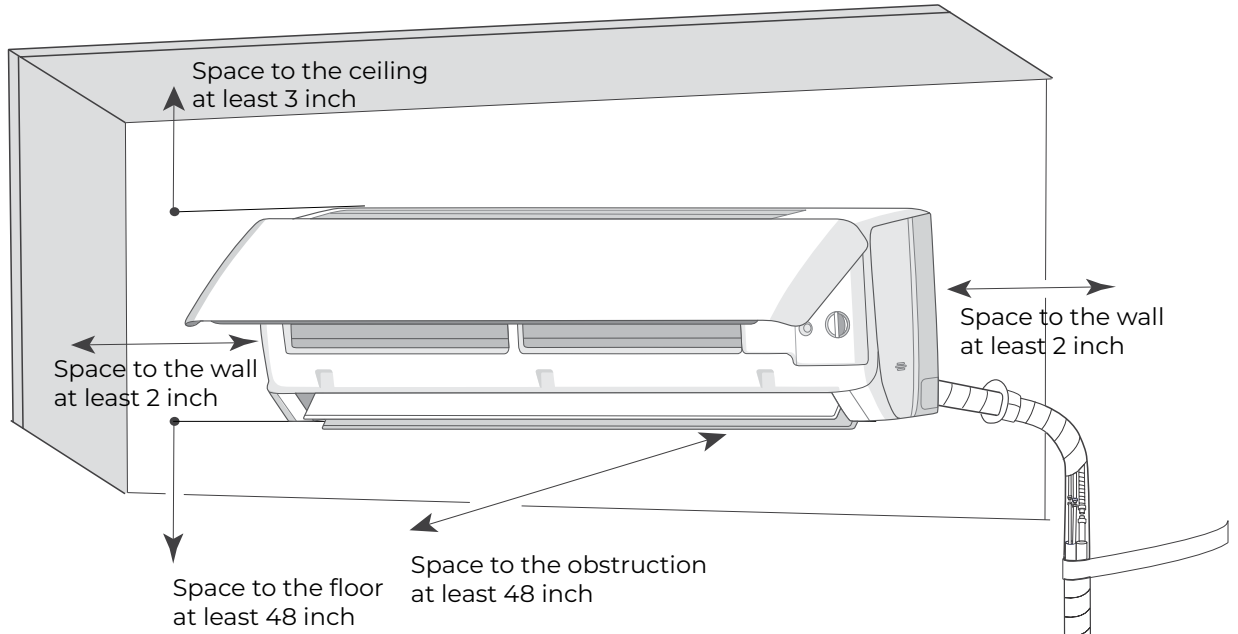

OUTDOOR UNIT Minimum clearance

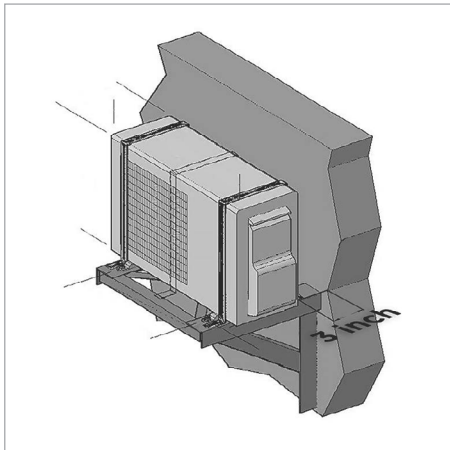

NOTE:
If bottom of the unit is free of airflow obstructions similar to the mounting bracket figure, the clearance to the wall on the back can be reduced to 3 inches.

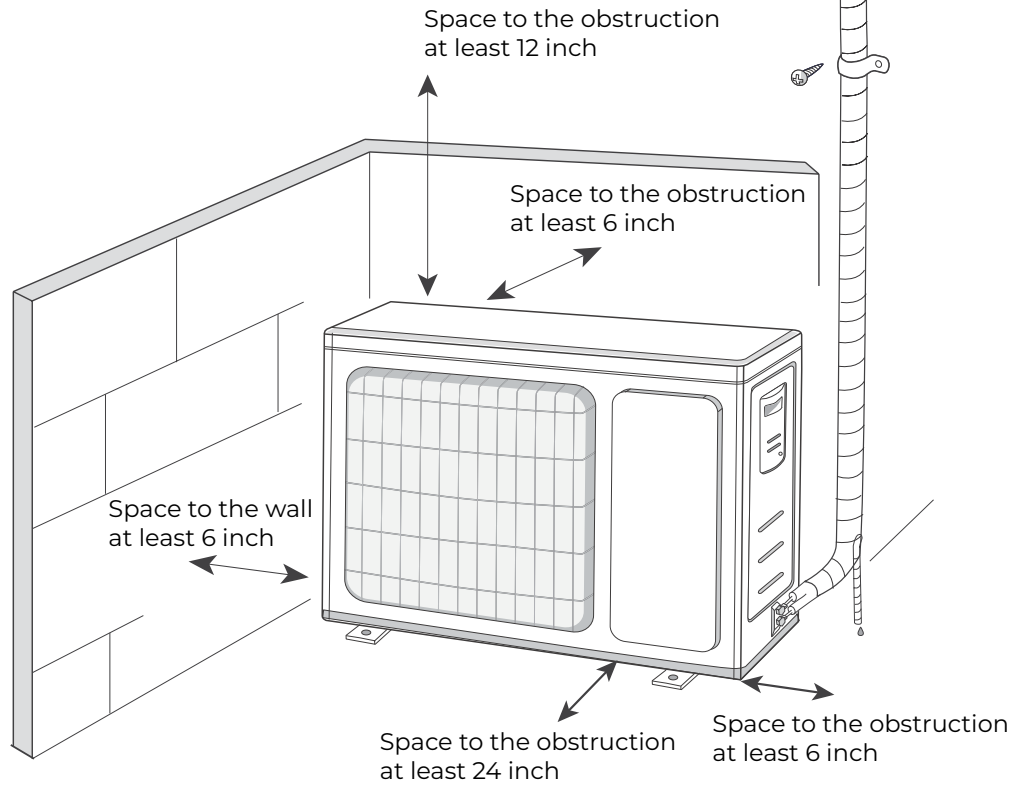

Specifications are subject to change without notice. Manufacturer reserves the right to discontinue or modify specifications or designs without notice or without incurring obligations. All Rights reserved.