

SUBMITTAL DATA

KUL09HPJ1321A / KUL09HPJ1320A
9000 BTU/H Wall Mounted Heat Pump System

Job Name

Purchaser

Submitted to

Unit Designation

Location

Date

Engineer

For

Schedule No.



KUL09HPJ1321A



KUL09HPJ1320A



YAP1F7F



XE71 (Optional)

GENERAL FEATURES

- AHRI Certificate: [215424784](#)
- High Efficiency DC Inverter Technology
- Compact and Quiet Design
- Auto-Clean Function on Indoor Unit
- Wireless Remote with LCD Display
- Wired Controller Options
- New R32 Refrigerant
- Composite Drain Pan
- Wi-Fi Included (Factory Installed)
- Low Ambient Cooling down to -20°F (Range -20°F to 122°F)
- Low Ambient Heating down to -22°F (Range -22°F to 86°F)
- Coil (Indoor and Outdoor) Copper Tube / Aluminum Fin
- Blue Colored Fin - 500 Hrs Salt Spray Tested

SPECIFICATIONS, FEATURES & FUNCTION SUMMARY

SYSTEM TYPE		HEAT PUMP		FEATURES & FUNCTIONS SUMMARY	
Outdoor Model		KUL09HPJ132OA		Inverter Type	G20
Indoor Model		KUL09HPJ132IA		Ultra Low Frequency Torque Control	Yes
SYSTEM PERFORMANCE					
Cooling Capacity	Min - Max	Btu/h	7,261 - 14,522		
	Capacity @95°F	Btu/h	9,100		
Heating Capacity	Min - Max	Btu/h	6,356 - 15,013		
	Capacity @47°F	Btu/h	10,500		
	Capacity @17°F	Btu/h	8,800		
	Capacity @5°F	Btu/h	9,500		
SEER2		26.0			
EER2		15.0			
HSPF2		10.4			
COP @5°F		1.88			
Cooling Temperature Range		°F	-20 - 122		
Heating Temperature Range		°F	-22 - 86		
Refrigerant Type		R32			
INDOOR UNIT		KUL09HPJ132IA			
Air flow (Min - Max)		CFM	194 - 353		
Sound Pressure Level (Min - Max)		dB(A)	20 - 41		
Dehumidification		pt/hr	1.69		
External Dimensions (W x H x D)		in	32-31/64 x 11-17/32 x 7-23/32		
Package Dimension (W x H x D)		in	34-29/64 x 14-3/8 x 10-35/64		
Net Weight		lbs	20.9		
Gross Weight		lbs	25.4		
OUTDOOR UNIT		KUL09HPJ132OA			
Compressor Type		G20 / SINGLE CYLINDER / 1 - STAGE INVERTER			
Sound Pressure Level		dB(A)	52		
External Dimensions (W x H x D)		in	31-37/64 x 21-27/32 x 13-25/32		
Package Dimension (W x H x D)		in	34-21/64 x 24-13/32 x 15-43/64		
Net Weight		lbs	70.6		
Gross Weight		lbs	76.1		
REFRIGERANT PIPING					
Refrigerant Charge - R32		oz	30		
Additional Charge		oz/ft	0.2		
Line Set Size (Liquid - Gas) - Flared Connections		in	1/4 - 3/8		
Pre-Charge Length		ft	25		
Pipe Length (Min - Max)		ft	10 - 66		
Max. Pipe Elevation		ft	40		
ELECTRICAL					
Power Supply		208-230V / 1Ph / 60Hz (Powered by the Outdoor Unit)			
Voltage Range (Min - Max)		VAC	187 - 253		
Rated Current - Cooling		A	4.73		
Rated Current - Heating		A	6		
MCA		A	10		
MOCP		A	15		
Suggested Breaker Size		A	10		
Main Power Wire Size		AWG	Per Local Code		
Interconnecting Wire Size		AWG	14 / 4		
REMOTE CONTROLLER FUNCTIONS					
NEW! Auto Clean		Yes			
Auto Mode		Yes			
Auto Fan		Yes			
Auto Swing (Horizontal Auto Swing)		Yes			
Auto Swing - 180° (Vertical Auto Swing)		Yes			
Clock		Yes			
Dry Mode		Yes			
Dry Anti-Mildew (X-Fan) Mode		Yes			
Energy Saving Mode		Yes			
Dirty Filter Alert		Yes			
Fan Speed Control		Yes			
I Feel Function		Yes			
Privacy Lock		Yes			
Quiet Mode		Yes			
Room Temperature Display		Yes			
Sleep Mode		Yes			
3 Sleep Mode Options		Yes			
Timer Mode		Yes			
Turbo Mode		Yes			
Display On/Off Control		Yes			
Freeze Guard Mode		Yes			
Power Failure Mode		Yes			
Humidity Control		Yes			

DIMENSIONS

INDOOR UNIT

Unit: inch

KUL09HPJ1321A	
DIMENSIONS	
W	32-31/64
H	11-17/32
D	7-23/32
W1	4-29/64
W2	21-11/32
W3	6-11/16

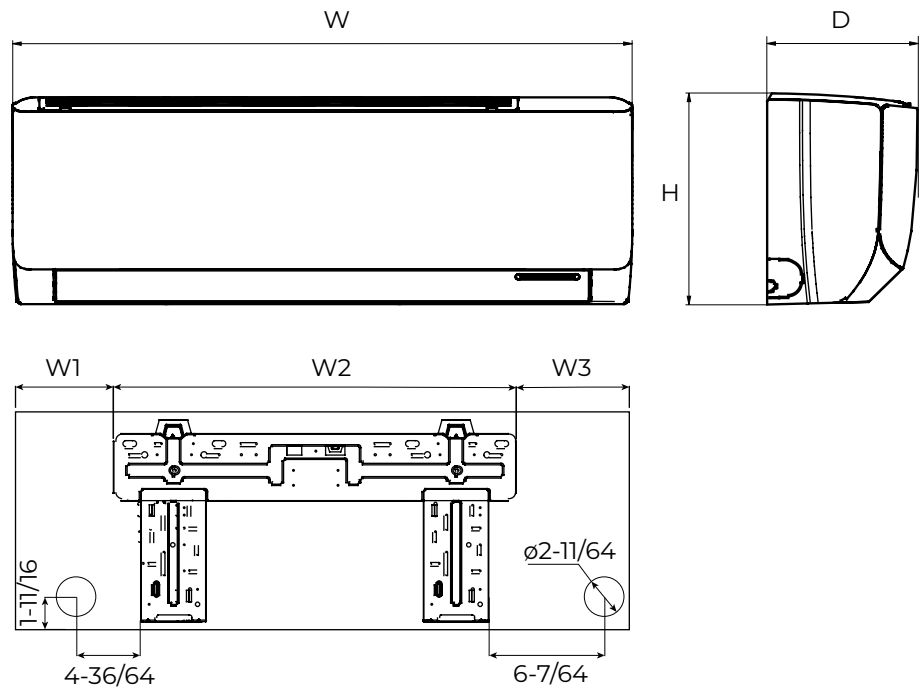

OUTDOOR UNIT

Unit: inch

KUL09HPJ1320A	
DIMENSIONS	
A	29-21/64
B	31-37/64
C	21-27/32
D	11-13/16
E	13-25/32
F	20-5/32
G	13-5/64

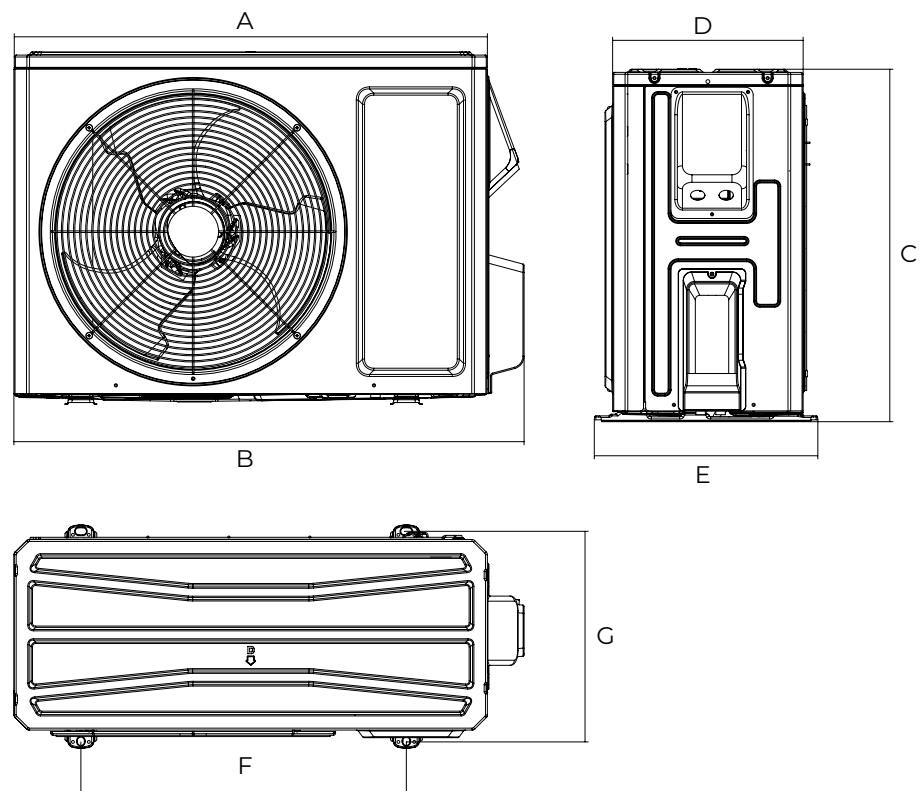

CLEARANCES

INDOOR UNIT Minimum clearance

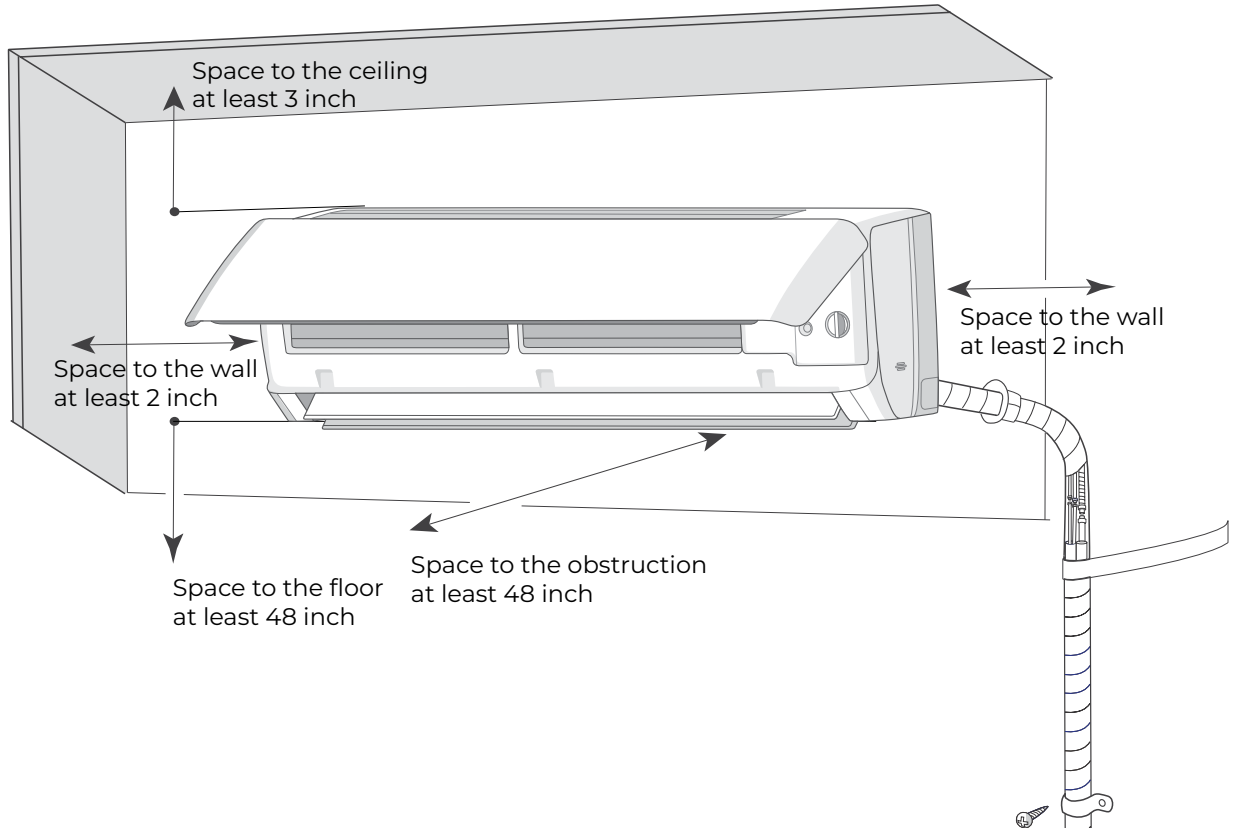

OUTDOOR UNIT Minimum clearance

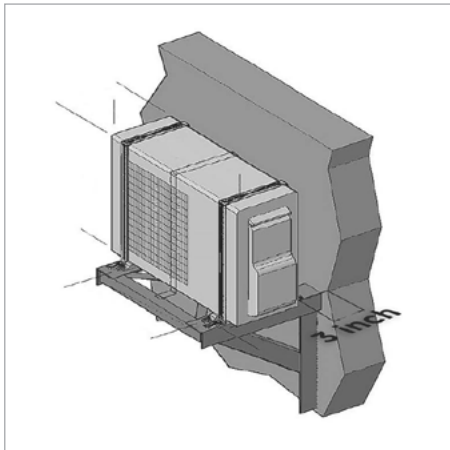

NOTE:
If bottom of the unit is free of airflow obstructions similar to the mounting bracket figure, the clearance to the wall on the back can be reduced to 3 inches.

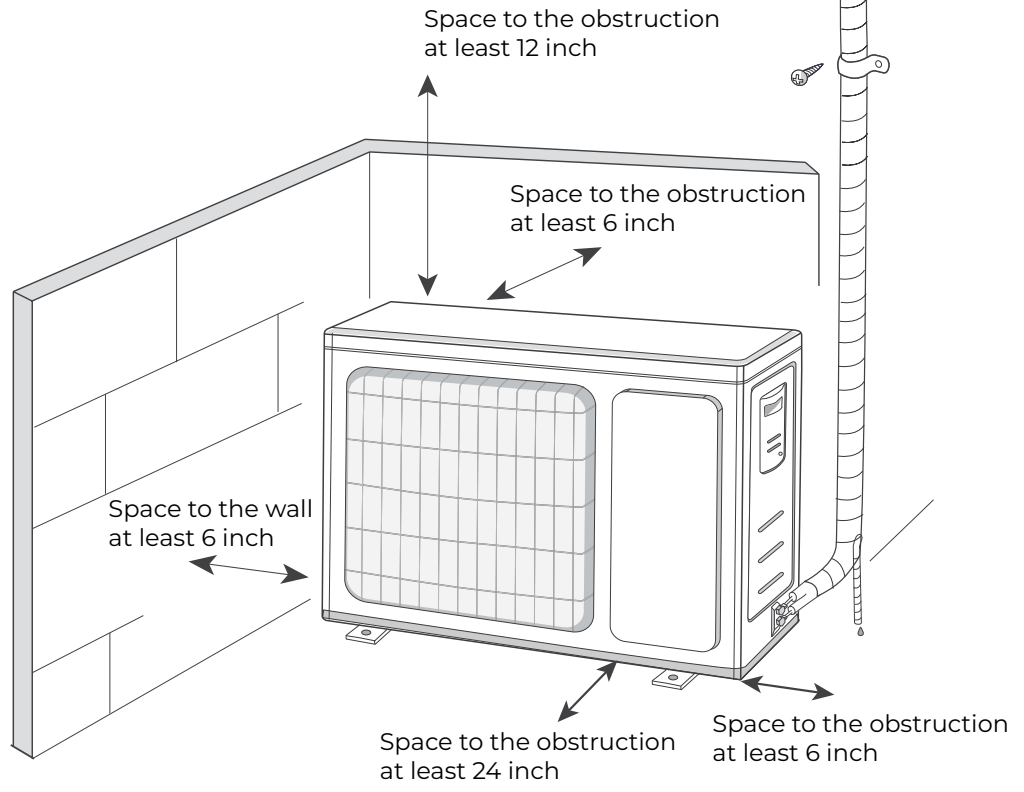

Specifications are subject to change without notice. Manufacturer reserves the right to discontinue or modify specifications or designs without notice or without incurring obligations. All Rights reserved.